

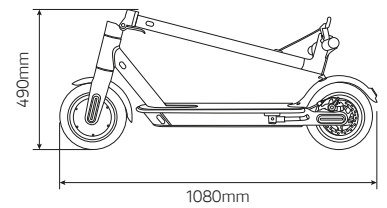

Urban
e-Mobility

PRO-I^{PLUS}
electric scooter

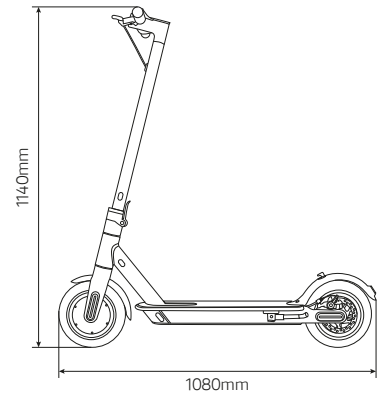

8.5" Wheels



Integrated display



Rear disc brake

Technical specifications

Product Sku: **M/DUC/PRO1P**
Ean Code: **8052870480279**

Basic info	
Frame material	Aluminum alloy 6061
Speed	ECO: <= 6km/h D: <= 20km/h S: <= 25km/h (max speed)
Maximum gradient	15%
Brakes	dual brake: front e-brake and rear disc brake
Power engine	250W
Tyre	8.5" front and rear inflatable tire
Low voltage protection	31V +/- 0.5V
Current limit	13A
Engine type	brushless
Max load	100kg
Safety information	from 14 years of age, 140/190cm height max, recommended use with helmet and protection.
Working Temperature	-10°C / 50°C
Level of protection	IP54
Charging time	about 5/6 hours
Autonomy	20-25km (subject to be variable by rider weight, road condition, temperature etc.)

Electric system	
Engine	250W Brushless
Brake	front electric brake
Display	LED display
Battery	36V, 7.8Ah, 280Wh
Lights	LED front and rear lights
Charger	EU Standard DC 2.1 Charger, 42V 2A

Dimensions and Weights	
Net weight	11.5kg
Gross weight	12.8kg
Unit size	1080 x 430 x 1140mm
Folding size	1080 x 430 x 490mm
Carton size	1150 x 190 x 500mm